

Synapse

AAD08

Dual Channel 1 to 8 Analog Audio Distribution Amplifier

Synapse

TECHNICAL MANUAL

AAD08

**Dual Channel 1 to 8
Analog Audio Distribution Amplifier**



Lange Wagenstraat 55

NL-5126 BB Gilze

The Netherlands

Phone: +31 161 850 450

Fax: +31 161 850 499

E-mail: Info@axon.tv

Web: www.axon.tv



WARNING: TO REDUCE THE RISK OF FIRE OR ELECTRICAL SHOCK, DO NOT EXPOSE THIS APPLIANCE TO RAIN OR MOISTURE

- ALWAYS disconnect your entire system from the AC mains before cleaning any component. The product frame (SFR18 or SFR04) must be terminated with three-conductor AC mains power cord that includes an earth ground connection. To prevent shock hazard, all three connections must always be used.
- NEVER use flammable or combustible chemicals for cleaning components.
- NEVER operate this product if any cover is removed.
- NEVER wet the inside of this product with any liquid.
- NEVER pour or spill liquids directly onto this unit.
- NEVER block airflow through ventilation slots.
- NEVER bypass any fuse.
- NEVER replace any fuse with a value or type other than those specified.
- NEVER attempt to repair this product. If a problem occurs, contact your local Axon distributor.
- NEVER expose this product to extremely high or low temperatures.
- NEVER operate this product in an explosive atmosphere.

Warranty: Axon warrants their products according to the warranty policy as described in the general terms. That means that Axon Digital Design BV can only warrant the products as long as the serial numbers are not removed.

Copyright © 2001 – 2006 AXON Digital Design B.V.

Date created: 19-12-01

Date last revised: 11-11-06

Axon, the Axon logo and Synapse are trademarks of Axon Digital Design B.V.

This product complies with the requirements of the product family standards for audio, video, audio-visual entertainment lighting control apparatus for professional use as mentioned below.

	EN60950	Safety
	EN55103-1: 1996	Emission
	EN55103-2: 1996	Immunity

<p>Axon Digital Design AAD08</p> <p> Tested To Comply With FCC Standards</p> <p>FOR HOME OR OFFICE USE</p>	<p>This device complies with part 15 of the FCC Rules Operation is subject to the following two conditions:</p> <p>(1) This device may cause harmful interference, and</p> <p>(2) This device must accept any interference received, including interference that may cause undesired operation.</p>
--	---

Table of Contents

Chapter 1	Introduction to Synapse	3
	An introduction to Synapse	3
	Local Control Panel	3
	Remote Control Capabilities	3
Chapter 2	Unpacking and Placement	4
	Unpacking	4
	Placing the card	4
Chapter 3	A Quick Start	5
	When powering-up	5
	Default settings	5
	Changing parameters and settings	5
	Front Panel Control	5
	Example of changing parameter using Front Panel control	5
	Synapse Setup Software	7
	Menu Structure Example	7
Chapter 4	The AAD08 cards	8
	Introduction	8
	Key Features	8
Chapter 5	Settings Menu	9
Chapter 6	Status Menu	11
Chapter 7	Events Menu	12
Chapter 8	LED Indication	15
Chapter 9	Block Schematic	16
Chapter 10	Connector panel	17

1 Introduction to Synapse

An Introduction to Synapse

Synapse is a modular system designed for the broadcast industry. High density, intuitive operation and high quality processing are key features of this system. Synapse offers a full range of converters and processing modules. Please visit the AXON Digital Design Website at www.axon.tv to obtain the latest information on our new products and updates.

Local Control Panel

The local control panel gives access to all adjustable parameters and provides status information for any of the cards in the Synapse frame, including the Synapse rack controller. The local control panel is also used to back-up and restore card settings. Please refer to the RRC18, RRC10 and RRC04 manuals for a detailed description of the local control panel, the way to set-up remote control over IP and for frame related settings and status information.

Remote Control Capabilities

The remote control options are explained in the rack controller (RRC18/RRC10/RRC04) manual. The method of connection to a computer using Ethernet is described in the RRC manual.



CHECK-OUT: “SYNAPSE SET-UP” SOFTWARE WILL INCREASE SYSTEM FLEXIBILITY OF ONE OR MORE SYNAPSE FRAMES

Although not required to Setup a Synapse frame, you are strongly advised to use a remote personal computer or laptop PC with the Synapse Setup software as this increases the ease of use and understanding of the modules.

2 Unpacking and Placement

Unpacking

The Axon Synapse card must be unpacked in an anti-static environment. Care must be taken NOT to touch components on the card – always handle the card carefully by the edges. The card must be stored and shipped in anti-static packaging. Ensuring that these precautions are followed will prevent premature failure from components mounted on the board.

Locating the card

The Synapse card can be placed vertically in an SFR18 frame or horizontally in an SFR04 frame. Locate the two guide slots to be used, slide in the mounted circuit board, and push it firmly to locate the connectors.

Correct insertion of card is essential as a card that is not located properly may show valid indicators, but does not function correctly.

NOTE: On power up all LED's will light for a few seconds, this is the time it takes to initialise the card.

3 A Quick Start

Power-up

On powering up the Synapse frame, the card set will use basic data and default initialisation settings. All LED's will light during this process. After initialisation, several LED's will remain lit – the exact number and configuration is dependant upon the number of inputs connected and the status of the inputs.

Default settings

In the default condition, the AAD08 will act as a dual channel 1 to 8 Analogue Audio Distribution Amplifier.

Changing settings and parameters

The front panel controls or the Synapse Set-Up Software can be used to change settings. An overview of the settings can be found in chapter 5, 6 and 7 of this manual.

Front Panel Control

Front Panel Display and Cursor

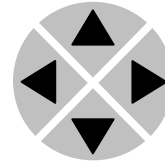
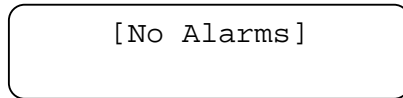

Settings are displayed and changed as follows;

Use the cursor 'arrows' on the front panel to select the menu and parameter to be displayed and/or changed.

- Press ► To go forward through the menu structure.
- Press ◀ To go back through the menu structure.
- Press ▲ To move up within a menu or increase the value of a parameter.
- Press ▼ To move down through a menu or decrease the value of a parameter.

NOTE: Whilst editing a setting, pressing ► twice will reset the value to its default.

Example of changing parameters using front panel control

With the display as shown below

```
RRC18 [Select Card]
>S01=SFS10
```

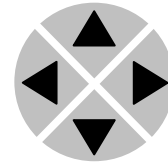

Pressing the ► selects the SFS10 in frame slot 01.

The display changes to indicate that the SFS10 has been selected. In this example the Settings menu item is indicated.

```
SFS10 [Select Menu]
>Settings
```

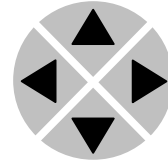

Pressing the ► selects the menu item shown, in this example Settings.

(Pressing ▲ or ▼ will change to a different menu eg Status, Events).

The display changes to indicate that the SFS10 Settings menu item SDI-Format has been selected and shows that its current setting is Auto.

```
SFS10 [Settings]
>SDI-Format=Auto
```

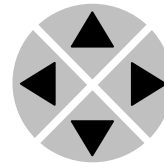

Pressing the ► selects the settings item shown, in this example SDI-Format.

(Pressing ▲ or ▼ will change to a different setting, eg Mode, H-Delay).

The display changes to indicate that the SFS10 Edit Setting menu item SDI-Format has been selected.

```
SFS10 [Edit
Setting]
```

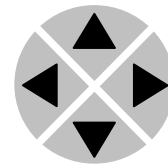

To edit the setting of the menu item press ▲ or ▼.

All menu items can be monitored and/or changed in this way. Changing a setting has an immediate effect.

Synapse Setup Software

Synapse Setup Software can be used to change the settings of Synapse modules from a PC, either locally or remotely. The software enables communication based on TCP/IP between the Setup PC and Synapse frames/modules.

Each Synapse frame is addressed through its rack controller's unique IP address, giving access to each module, its menus and adjustment items. The Synapse Setup software has access to data contained within the Synapse module and displays it on a GUI. The software has an intuitive structure following that of the module that it is controlling.

Having selected the desired Frame and Module from the GUI Synapse Network View, select the menu item that you wish to open. Opening the menu item gives a complete list of available properties with their associated Value.

For example to change a setting e.g. SDI-Format, select SDI-Format from the list of settings by 'double clicking' to open a dialogue box. The dialogue box allows parameters to be changed or set to default value. On completion close the dialogue box.

Menu Structure Example

Slot	Module	Item	Parameter	Setting
▲				
▲				
S02		Identity		
▲				
S01	SFS10	Settings	SDI-Format	Auto
▼				
S00	RRC18	Status	Mode	625
		Events	Ref-Input	525
			H-Delay	

NOTE: Further information about Front Panel Control and Synapse Setup Software can be obtained from the RRC18 and RRC04 operational manuals.

4 The AAD08 Card

Introduction	<p>The Axon AAD08 Analog Audio Distribution Amplifier, provides dual channel 8 way distribution. It utilises high quality components to provide high reliability and excellent audio performance.</p> <p>The AAD08 features Transformer couple inputs, Variable Gain, Peak Detection and Silence Detection.</p>
Key Features	<p>The Key features of the AAD08 are as follows:</p>
High Quality performance	<p>The AAD08 uses high quality analogue components to ensure that the signal path has low distortion and a high signal to noise ratio.</p>
Transformer coupled Inputs	<p>The two inputs of the AAD08 are transformer coupled.</p>
Variable Gain	<p>The AAD08 can amplify or attenuate the output signal to ensure that the appropriate audio level is maintained</p>
Peak Detection	<p>The level at which peaks are detected can be set using the peak detection circuitry.</p>
Silence Detection	<p>The level at which silence is detected can be set using the silence detection circuitry</p>
Back planes	<p>The AAD08 can be used with the BPL06 back plane.</p>
Miscellaneous	<p>The AAD08 cards fit into the Axon SFR04 & SFR18 rack.</p> <p>LED's on the front of the board indicate the presence of an Audio Input signal, Connection & Processor Errors.</p> <p>The AAD08 can be controlled by Axon Synapse set-up software.</p>

5 Settings Menu

Introduction	<p>The settings menu displays the current state of each setting within the AAD08 and enables the item to be changed or adjusted.</p> <p>Settings can be changed using the front panel of the Synapse frame (SFR18 or SFR04) or Synapse Setup software.</p> <p>Please refer to chapter 3 for information on the Synapse front panel control and Synapse Setup software.</p>
Gain-CH_1	<p>The settings menu item Gain-CH_1 controls the output gain of channel 1, the left channel. Gain-CH_1 has an adjustment range between -95.5dB and $+31.5\text{dB}$ (in 0.5 dB steps). When Gain-CH_1 is set to 0dB the output level is equal to the input level. The default setting of Gain-CH_1 is 0dB.</p>
Gain-CH_2	<p>The settings menu item Gain-CH_2 controls the output gain of channel 2, the right channel. Gain-CH_2 has an adjustment range between -95.5dB and $+31.5\text{dB}$ (in 0.5 dB steps). When Gain-CH_2 is set to 0dB the output level is equal to the input level. The default setting of Gain-CH_2 is 0dB.</p>
Peak-CH_1	<p>Peak-CH_1 adjusts the threshold of the peak detection circuitry used to trigger Status and Event conditions (see later). The adjustment range of Peak-CH_1 is between 0dBu and $+24\text{dBu}$. The default setting of Peak-CH_1 is 24dBu.</p>
Peak-CH_2	<p>Peak-CH_2 adjusts the threshold of the peak detection circuitry used to trigger Status and Event conditions (see later). The adjustment range of Peak-CH_2 is between 0dBu and $+24\text{dBu}$. The default setting of Peak-CH_2 is 24dBu.</p>
Silence-CH_1	<p>The setting Silence-CH_1 sets the level of the silence detection circuitry used to trigger Status and Event conditions (see later). The adjustment range of Silence-CH_1 is between -27.5dBu and -50dBu. The default setting of Silence-CH_1 is -30dBu.</p>

Silence-CH_2

The setting `Silence-CH_2` sets the level of the silence detection circuitry used to trigger Status and Event conditions (see later). The adjustment range of `Silence-CH_2` is between -27.5dBu and -50dBu . The default setting of `Silence-CH_2` is -30dBu .

Mute

The menu item `Mute` activates a mute when set to `On`. Both channels will be muted. The default setting of `Mute` is `Off`.

6 Status Menu

Introduction	The status menu indicates the current status of each item listed below.
Audio-CH_1	<p>The status item <code>Audio-CH_1</code> indicates the condition of an analog audio signal at the input of channel 1. <code>Audio-CH_1</code> indicates if the input signal is <code>OK</code>, <code>Peak</code> or <code>NA</code> (not available).</p> <p>The level at which <code>Peak</code> will be indicated is set by the corresponding Menu Settings, <code>Peak-CH_1</code>, please refer to Chapter 5. The indication <code>NA</code> indicates the channel is silent, the silence level is set by the corresponding Menu Settings, <code>Silence-CH_1</code>, please refer to Chapter 5.</p>
Audio-CH_2	<p>The status item <code>Audio-CH_2</code> indicates the condition of an analog audio signal at the input of channel 2. <code>Audio-CH_2</code> indicates if the input signal is <code>OK</code>, <code>Peak</code> or <code>NA</code> (not available).</p> <p>The level at which <code>Peak</code> will be indicated is set by the corresponding Menu Settings, <code>Peak-CH_2</code>, please refer to Chapter 5. The indication <code>NA</code> indicates the channel is silent, the silence level is set by the corresponding Menu Settings, <code>Silence-CH_2</code>, please refer to Chapter 5.</p>

7 Events Menu

Introduction	An event is a special message that is generated on the card asynchronously. This means that it is not the response to a request to the card, but a spontaneous message.
What is the Goal of an event?	The goal of events is to inform the environment about a changing condition on the card. A message may be broadcast to mark the change in status. The message is volatile and cannot be retrieved from the system after it has been broadcast. There are several means by which the message can be filtered.
AAD08 Events	The events reported by the AAD08 are as follows;
Announcements	Announcements is not an event. This item is only used for switching the announcement of status changes on/off. 0=off, other =on
Input_CH1	Input_CH1 reports the loss of the audio at the input of channel 1 by detecting Silence and can be set between 0 .. 255. 0= no event, 1..255 is the priority setting.
Input_CH2	Input_CH2 reports the loss of the audio at the input of channel 2 by detecting Silence and can be set between 0 .. 255. 0= no event, 1..255 is the priority setting.
Audio-Data_CH1	Audio-Data_CH1 reports if channel 1 audio has reached the Peak level set by the setting item Peak-CH_1 and can be set between 0 .. 255. 0= no event, 1..255 is the priority setting.
Audio-Data_CH2	Audio-Data_CH2 reports if channel 2 audio has reached the Peak level set by the setting item Peak-CH_2 and can be set between 0 .. 255. 0= no event, 1..255 is the priority setting.

What information is available in an event?

The message consists of the following items;

- 1) A message string to show what has happened in text, for example: “INP_LOSS”, “REF_LOSS”, “INP_RETURN”.
- 2) A tag that also shows what happens, but with a predefined number: e.g. 1 (= loss of input), 2 (= loss of reference), 129(= 1+128 = return of input). For a list of these predefined tags see the table on the next page.
- 3) A priority that marks the importance of an event. This value is defined by the user and can have any value between 1 and 255, or 0 when disabled.
- 4) A slot number of the source of this event.

The Message String

The message string is defined in the card and is therefore fixed. It may be used in controlling software like Synapse Set-up to show the event.

The Tag

The tag is also defined in the card. The tag has a fixed meaning. When controlling or monitoring software should make decisions based on events, it is easier to use the tag instead of interpreting a string. The first implementation is the tag controlled switch in the GPI16.

In cases where the event marks a change to fault status (e.g. 1 for Loss of Input) the complement is marked by the tag increased by 128 (80_{hex}) (e.g. 129 (81_{hex}) for Return of Input).

Defining Tags

The tags defined for the AAD08 are:

Event Menu Item	Tag		Description
Announcements	0 or NA	0 or NA	Announcing of report and control values
Input_CH1	01 _{hex} =INP_LOSS	81 _{hex} =INP_RETURN	Ch 1 input lost or returned
Input_CH2	01 _{hex} =INP_LOSS	81 _{hex} =INP_RETURN	Ch 2 input lost or returned
Audio-Data_CH1	05 _{hex} =AUDIO_ERROR	85 _{hex} =AUDIO_OK	Audio data error
Audio-Data_CH2	05 _{hex} =AUDIO_ERROR	85 _{hex} =AUDIO_OK	Audio data error

The Priority

The priority is a user-defined value. The higher the priority of the alarm, the higher this value. Setting the priority to Zero disables the announcement of this alarm. Alarms with priorities equal or higher than the Error Threshold setting of the RRC will cause the error LED on the Synapse rack front panel to light.

The Address

Together with the message string or the tag, the slot number or address of the card is relevant to be able to assign the event to a certain card.

8 LED Indication

Error LED	The error LED indicates an error if the internal logic of the AAD08 card is not configured correctly or has a hardware failure.
Input LED	This LED indicated the presence of a valid analog audio signal on the input.
Data Error	The Data Error LED indicates that the Peak Level or Silence Level as set in the settings menu has been reached.
Connection LED	This LED illuminates after the card has initialised. The LED lights for 0.5 seconds every time a connection is made to the card.

9 Block Schematic

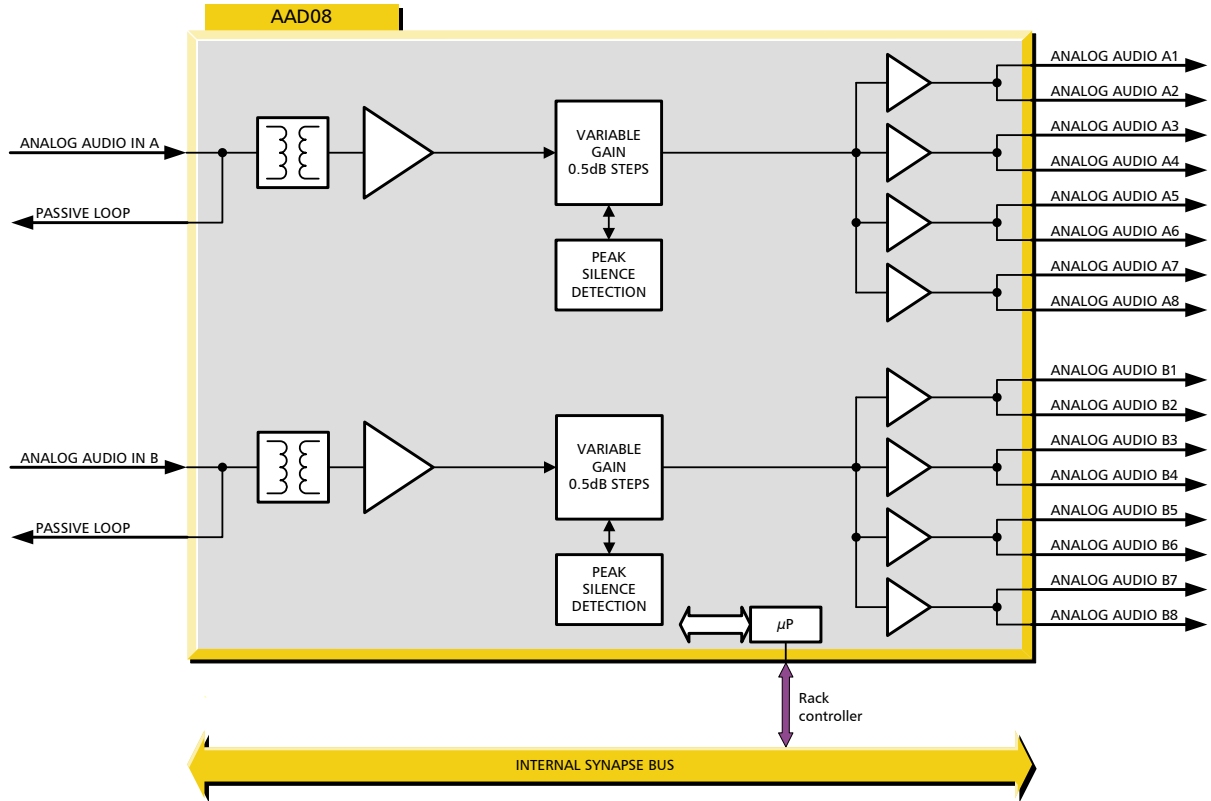

10 Connector Panel

The AAD08 can be used with the following backplane: BPL06, BPL06M.

BPL06

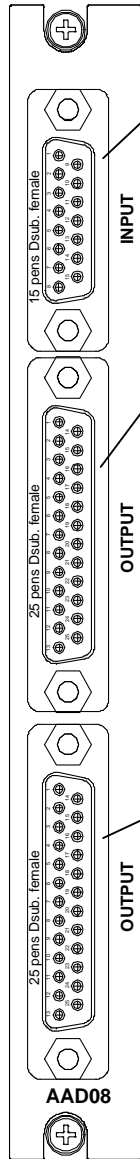

		Pin No. Pos	Pin No. Neg	Pin No. gnd
CN101				
Input	CHA	2	1	9
	CHB	14	13	6
Loop	CHA	11	10	3
	CHB	8	7	15
CN102				
Output	CHA	1	2	14
	CHA	15	16	3
	CHB	4	5	17
	CHB	18	19	6
	CHA	7	8	20
	CHA	21	22	9
	CHB	10	11	23
	CHB	24	25	12
CN103				
Output	CHA	1	2	14
	CHA	15	16	3
	CHB	4	5	17
	CHB	18	19	6
	CHA	7	8	20
	CHA	21	22	9
	CHB	10	11	23
	CHB	24	25	12

BPL06M

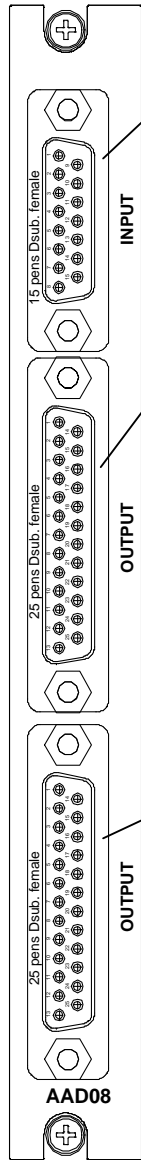

		Pin No. Pos	Pin No. Neg	Pin No. gnd
CN101				
Input	CH1	2	1	9
	CH2	14	13	6
Loop	CH1	11	10	3
	CH2	8	7	15
CN102				
Output	CHA	1	2	14
	CHA	15	16	3
	CHA	4	5	17
	CHA	18	19	6
	CHA	7	8	20
	CHA	21	22	9
	CHA	10	11	23
	CHA	24	25	12
CN103				
Output	CHB	1	2	14
	CHB	15	16	3
	CHB	4	5	17
	CHB	18	19	6
	CHB	7	8	20
	CHB	21	22	9
	CHB	10	11	23
	CHB	24	25	12