



DAD08/09

**Digital (AES/EBU) audio distribution amplifier
(08 has transformer coupled outputs)**

A Synapse® product

The word "Synapse" written in a light blue, cursive script font with a slight drop shadow.

COPYRIGHT ©2008 AXON DIGITAL DESIGN BV

ALL RIGHTS RESERVED

NO PART OF THIS DOCUMENT MAY BE REPRODUCED IN ANY FORM
WITHOUT THE PERMISSION OF AXON DIGITAL DESIGN BV.

Block schematic & I/O panel

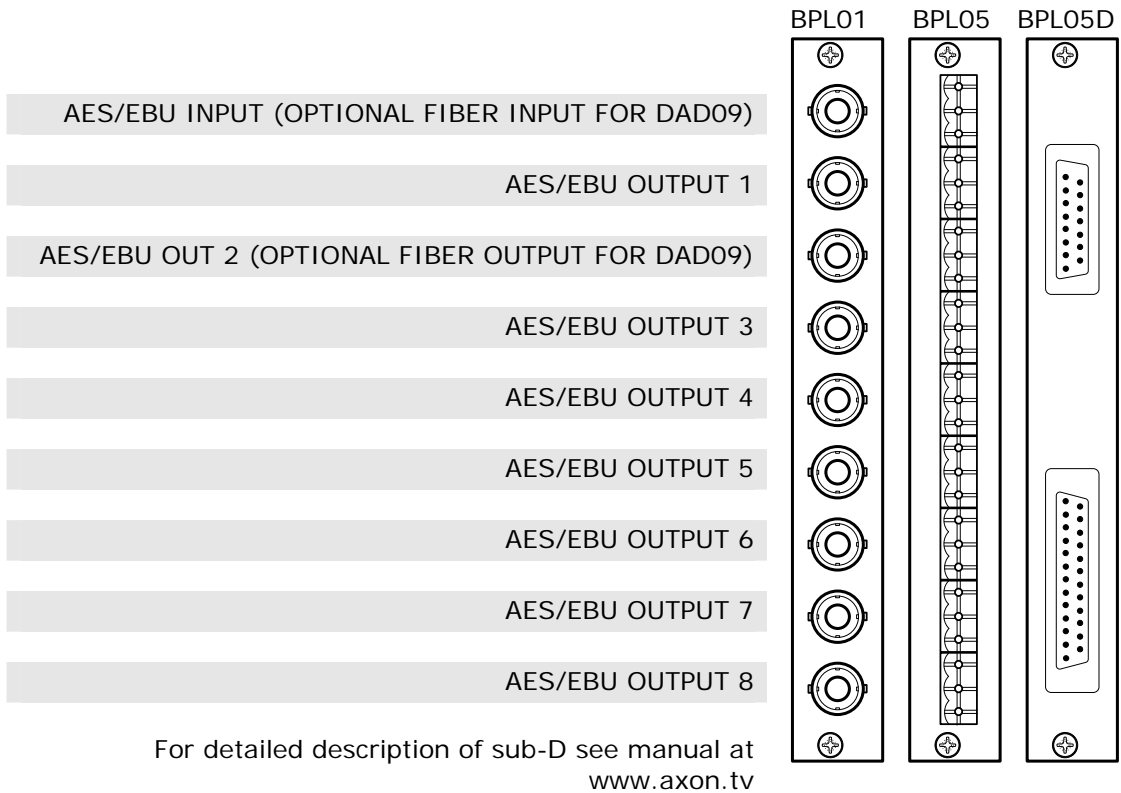
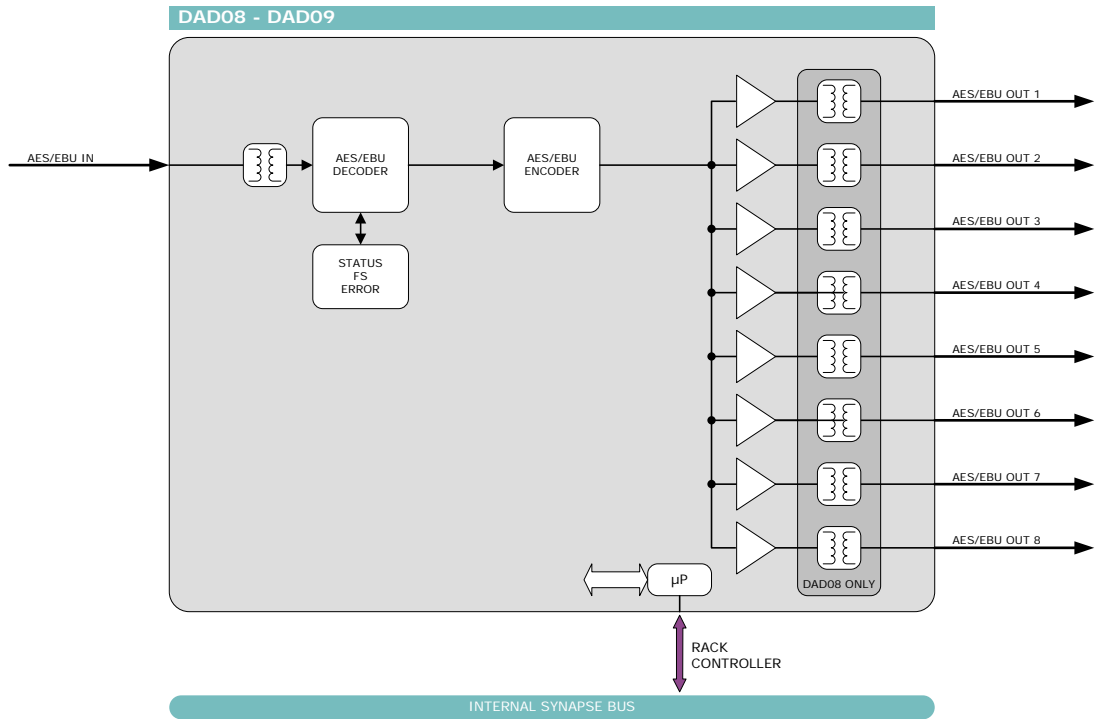

Features

The DAD08 and DAD09 are digital audio distribution amplifiers that distribute a single input to eight outputs. The DAD08/09 accepts AES/EBU or SPDIF (Consumer Interface Format) digital audio input that is then reclocked, buffered and distributed to the eight outputs. The DAD08 has transformer coupled balanced input and outputs, whereas the DAD09 has a transformer coupled balanced input and direct balanced outputs. Multiple regenerated independent low jitter outputs make the DAD08 and DAD09 ideal for the most demanding digital audio signal distribution requirements in both large and small audio and video facilities. Balanced or unbalanced use is automatically selected by use of the appropriate connector panel.

- 8 outputs
- Transformer coupled input
- Transformer coupled outputs (on DAD08 only)
- 32 to 96 kHz compatibility
- Signal present indication
- Sample frequency indication
- Compatible with 110 Ohms and 75 Ohms environments
- Full control and status monitoring through the front panel of the SFR04/SFR08/SFR18 frame and the Ethernet port (ACP)
- Optional 1 fiber input (replacing 1 SDI input) or 1 fiber output (replacing 1 SDI output) on I/O panel; DAD09 only.

Applications

- Generic digital audio distribution

Ordering information

Modules:

- **DAD08:** Digital (AES/EBU) audio distribution amplifier with transformed coupled outputs
- **DAD09:** Digital (AES/EBU) audio distribution amplifier

Standard I/O:

- **BPL01_DAD08:** I/O panel for DAD08 with unbalanced AES/EBU in and unbalanced AES/EBU out.
- **BPL05_DAD08:** I/O panel for DAD08 with balanced AES/EBU in and balanced AES/EBU out.
- **BPL05D_DAD08:** I/O panel for DAD08 with balanced AES/EBU in and balanced AES/EBU out on sub-D
- **BPL01_DAD09:** I/O panel for DAD09 with unbalanced AES/EBU in and unbalanced AES/EBU out.
- **BPL05_DAD09:** I/O panel for DAD09 with balanced AES/EBU in and balanced AES/EBU out.
- **BPL05D_DAD09:** I/O panel for DAD09 with balanced AES/EBU in and balanced AES/EBU out on sub-D

Fiber outputs:

- **BPL01T_FC/PC_DAD09:** I/O panel for DAD09 with fiber transmitter on FC/PC
- **BPL01T_SC_DAD09:** I/O panel for DAD09 with fiber transmitter on SC

Fiber inputs:

- **BPL01R_FC/PC_DAD09:** I/O panel for DAD09 with fiber receiver on FC/PC
- **BPL01R_SC_DAD09:** I/O panel for DAD09 with fiber receiver on SC

Specifications

AES Audio Input

Connector Standard	BNC, Screw terminal or sub-D (balanced) AES-1992 for balanced synchronous or asynchronous PCM/AES, SMPTE 276M for single ended synchronous or asynchronous PCM/AES
Number of Inputs	1
Sampling Rate	32 kHz to 96 kHz
Resolution	24 bits
Minimum Input/Output Delay	4 samples
Impedance	110 Ohms or 75 Ohms
Level	0.2V to 1V nom for BNC, 2V to 7V for balanced operation

AES Audio Output

Number of Outputs	1
Connector	BNC, Screw terminal or female sub-D (balanced)
Resolution	24 bits
Sampling Rate	Equal to input

Miscellaneous

Weight	Approx. 250g
Operating Temperature	0 °C to +50 °C
Dimensions	137 x 296 x 20 mm (HxWxD)

Electrical

Voltage	+24V to +30V
Power	<3 Watts