



DIO48

**8 channel digital audio (192kHz) sample rate converter,
tracking (and offset) delay - ADD-ON card**

A Synapse® product

Synapse

**ADD-ON
Card**

COMPATIBLE WITH
 **DOLBY. E**

COPYRIGHT ©2008 AXON DIGITAL DESIGN BV

ALL RIGHTS RESERVED

NO PART OF THIS DOCUMENT MAY BE REPRODUCED IN ANY FORM
WITHOUT THE PERMISSION OF AXON DIGITAL DESIGN BV.

Block schematic & I/O panel

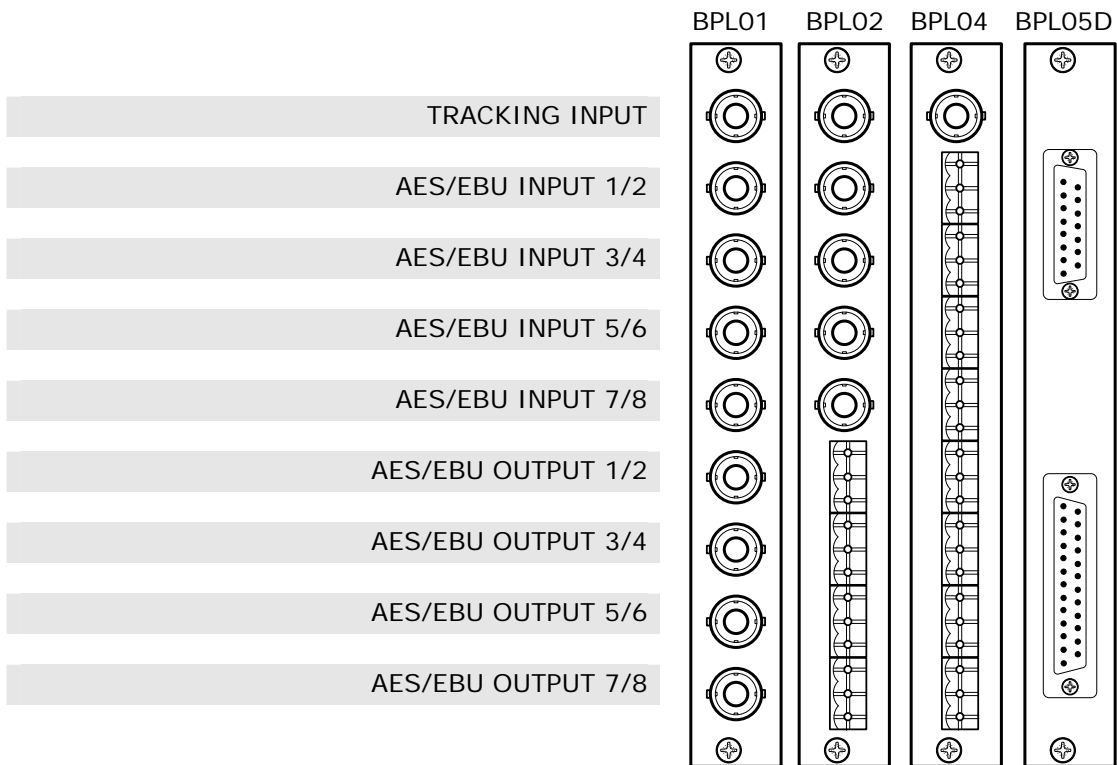
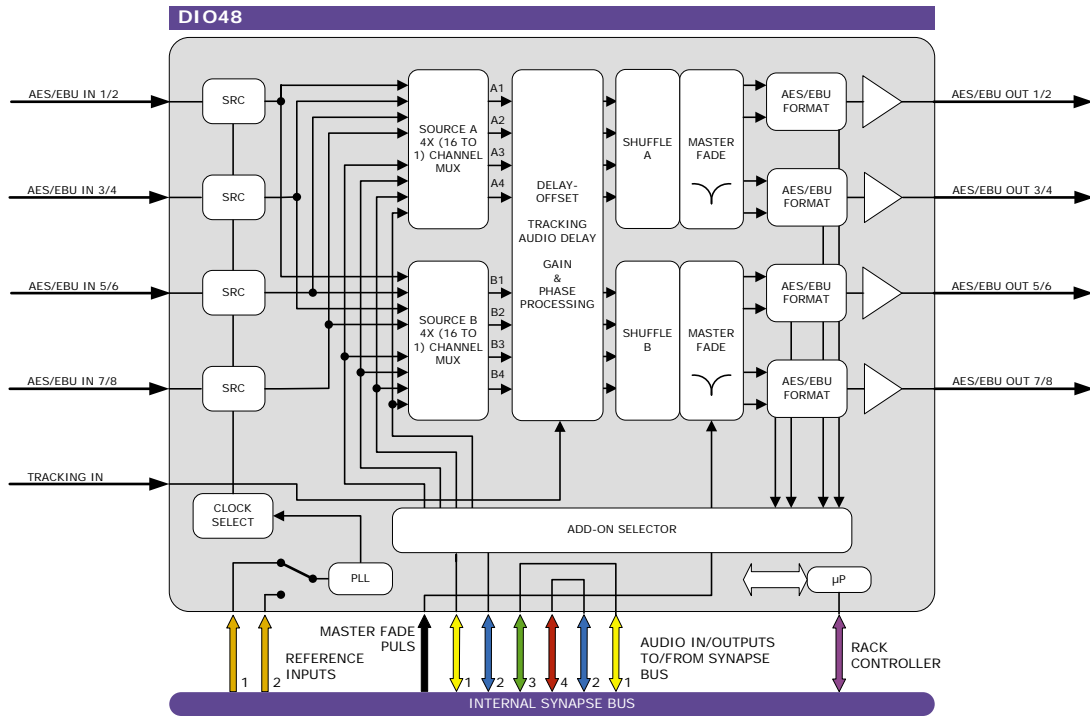

Features

The DIO48 is a multi-functional product. Its basic function is the conversion of asynchronous AES/EBU digital audio into synchronous AES/EBU utilizing the on-board sample rate converter. The DIO48 has a tracking audio delay, with a delay offset possibility of up to 5200ms, and it can perform the Synapse ADD-ON input and output function. Also provided in this module is shuffling and mixing of the AES channels. This board can be used as an input or output ADD-ON board

- Selection of 8 channels out of all local and ADD-ON inputs
- Full mixing capabilities of 2 x 4 channels (A and B)
- AES/EBU inputs with optional SRC (32 to 192kHz sampling)
- Sample clock can be derived from master card (ADD-ON mode)
- 48kHz sample clock locked to: B&B ref or word clock ref.
- 48kHz sample clock in free running mode
- Available with 110 Ohms (phoenix or sub-D) or 75 Ohms (BNC) AES/EBU in- and outputs
- Adjustable audio gain (in 0.25dB) and phase (0-180 deg)
- Can be used as a Synapse ADD-ON input or output card
- Adjustable audio delay offset up to 1300ms in 1ms increments
- Tracking audio delay on dedicated BNC input
- Master fade function for dedicated Synapse applications
- Full control and status monitoring through the front panel of the SFR04/SFR08/SFR18 frame and the Ethernet port (ACP)

Applications

- Can be used as an independent audio delay with tracking possibility
- Can be used as a four channel sample rate converter
- 8 channel ADD-ON input card to the HXT10 (and many other 2 group embedding master cards)

Ordering information

Module:

- **DIO48:** 8 channel digital audio (192kHz) sample rate converter, tracking (and offset) delay - ADD-ON card

Standard I/O:

- **BPL01_DIO48:** I/O panel for DIO48 with unbalanced AES/EBU in and out
- **BPL02_DIO48:** I/O panel for DIO48 with unbalanced AES/EBU in and balanced AES/EBU out
- **BPL04_DIO48:** I/O panel for DIO48 with balanced AES/EBU in and balanced AES/EBU out
- **BPL05D_DIO48:** I/O panel for DIO48 with balanced AES/EBU in and balanced AES/EBU out on sub-D

Specifications

AES Audio Input

Connector Standard	BNC, Screw terminal or female sub-D (balanced) AES-1992 for balanced synchronous or asynchronous PCM/AES, SMPTE 276M for single ended synchronous or asynchronous PCM/AES
Number of Inputs	4
Sampling Rate	32 kHz to 192 kHz Synchronous 48 kHz in Master/ADD-On mode
Resolution	24 bits when AES inputs selected, 20 bits in Master/ADD-ON mode
Minimum Input/Output Delay	1 ms
Impedance	110 Ohms or 75 Ohms
Level	0.2V to 1V nom for BNC, 2V to 7V for balanced operation

AES Audio Output

Number of Outputs	4
Connector	BNC, Screw terminal or female sub-D (balanced)
Resolution	24 bits
Sampling Rate	48KHz synchronous
Minimum Input/Output Delay	2.5ms
Maximum Input/Output Delay	5200 ms

Reference Video Input

Standard	PAL (ITU624-4), NTSC (SMPTE 170M) Word clock 48k square-wave
Number of Inputs	2 on SFR18, 2 on SFR08, 1 on SFR04
Connector	BNC
Signal Level	1V nominal
Impedance	75 Ohms
Return Loss	> 25dB to 10MHz

Miscellaneous

Weight	Approx. 250g
Operating Temperature	0 °C to +50 °C
Dimensions	137 x 296 x 20 mm (HxWxD)

Electrical

Voltage	+24V to +30V
Power	<4 Watts