



HSU11

HD up-converter with color corrector and 2 group embedder

A Synapse® product

The logo for Synapse, written in a light blue, cursive script font.



COPYRIGHT © 2008 AXON DIGITAL DESIGN BV

ALL RIGHTS RESERVED

NO PART OF THIS DOCUMENT MAY BE REPRODUCED IN ANY FORM
WITHOUT THE PERMISSION OF AXON DIGITAL DESIGN BV.

Block schematic & I/O panel

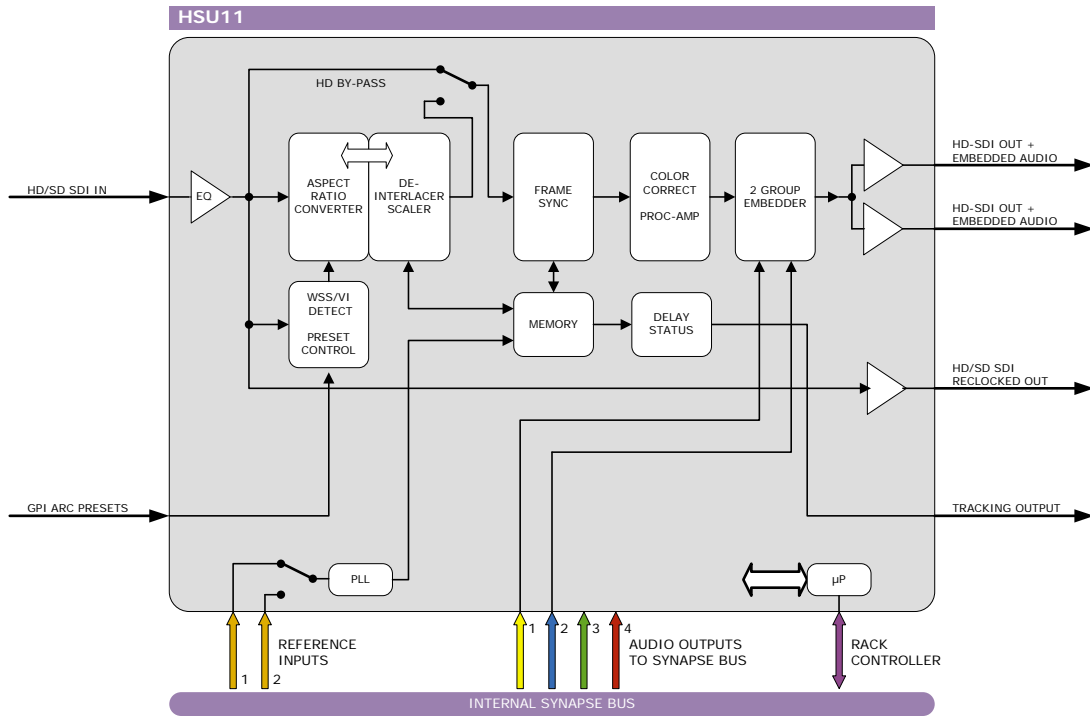

HD/SD SDI INPUT (OPTIONAL FIBER INPUT)

HD/SD-SDI RECLOCKED OUTPUT

HD-SDI PROCESSED OUTPUT 1

HD-SDI PROCESSED OUTPUT 2 (OPTIONAL FIBER OUTPUT)

TRACKING OUTPUT

GPI ARC PRESET CONTROL

For fiber connectivity see www.axon.tv

BPH03

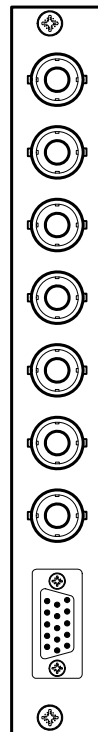

Features

The HSU11 is high-quality up converter. The optimized scaling and filter algorithms ensure crisp broadcast ready pictures from a native SD source, by use of a 64 tap FIR filters. The HSU11 will allow you to simulcast HD signals from a native SD infrastructure. The embedded audio is carried over to the HD domain. The appropriate aspect ratio can be applied by control of VI, WSS and GPI inputs by use of 16 presets that can store the aspect ratio conversions. Additionally, the HSU11 contains a 2 group embedder which enables you to embed audio from the Synapse bus.

- HD-SDI or SD-SDI input (auto by-pass mode with no processing)
- 625/50 to 1080i/50 or 720p/50
- 525/59.94 to 1080i/59.94 or 720p/59.94
- 625/50 to 1080p/25 or 720p/25
- 525/59.94 to 1080p/29.97 or 720p 29.97
- Single field (low latency) and 3 field de-interlacing
- Sharpness control for crisp image quality
- Low latency mode with 54 SD lines delay
- Adjustable H and V delay with respect to input or reference
- Color corrector
- Aspect ratio control:
 - Embedded WSS
 - Embedded WSS-ext
 - Embedded VI
 - GPI (BPH03)
- 16 presets for aspect ratio conversion
 - Anamorphic (16F16 to 16F16)
 - Pillarbox (12F12 to 12P16)
 - Pillarbox 14:9 (12F12 to 14P16)
 - Inverse pan-scan (12F12 to 16F16)
- V position control between -128 and + 127 lines (for inverse pan-scan/zoom mode)
- Jump to preset or hold at loss of WSS or VI control
- 2 group embedding from Synapse bus
- Automatic Correct color space conversion(601-709)
- VITC transparency with selectable line selection and duplication
- One reclocked output (active loop)
- 2 HD-SDI processed outputs (active loop in HD by-pass mode)
- Built-in ARC for 4:3 and 14:9 pillar box and inverse pan scan output formats (SD only)
- Full control and status monitoring through the front panel of the SFR04/SFR08/SFR18 frame and the Ethernet port (ACP)
- Optional 1 fiber input (replacing 1 SDI input) or 1 fiber output (replacing 1 SDI output) on I/O panel

Complementary cards:

- ADC20, ADC24, DIO24, DIO48

Conversion abilities

The HSU11 can handle the following conversions:

CONVERSION		Output				
		1080i59.94	1080i50	720p59.94	720p50	480i59.94(525) 576i50(625)
Input	1080i59.94	x				
	1080i50		x			
	720p59.94			x		
	720p50				x	
	480i59.94(525)	x		x		x
	576i50(625)		x		x	x

Applications

- High quality low latency up-conversion (with zero motion artifacts)
- Free running fill-in camera positions up-conversion and synchronization

Ordering information

Module:

- **HSU11:** HD up-converter with color corrector and 2 group embedder

Standard I/O:

- **BPH03_HSU11:** I/O-panel for HSU11

Fiber outputs:

- **BPH03T_FC/PC_HSU11:** I/O-panel for HSU11 with fiber transmitter on FC/PC
- **BPH03T_SC_HSU11:** I/O-panel for HSU11 with fiber transmitter on SC

Fiber inputs:

- **BPH03R_FC/PC_HSU11:** I/O-panel for HSU11 with fiber receiver on FC/PC
- **BPH03R_SC_HSU11:** I/O-panel for HSU11 with fiber receiver on SC

Specifications

HD/SD Serial Video Input

Standard	625/50 or 525/59.94 SMPTE 259M-C (270Mb/s) with SMPTE 272M embedded audio SMPTE 292M (1.5Gb/s), SMPTE 260M, SMPTE 274M, SMPTE 296M, SMPTE 349M 1080i/59.94, 1080i/50, 720p/59.94, 720p/50
Number of Inputs	1
Equalization	Automatic to 150m @ 1.5Gb/s with Belden 1694A or equivalent cable.
Return Loss	> 15dB up to 1.5GHz

HD Serial Video Output

Standard	SMPTE 292M (1.5Gb/s), SMPTE 260M, SMPTE 274M, SMPTE 296M, SMPTE 349M 1080i/59.94, 1080i/50, 720p/59.94, 720p/50
Number of Outputs	3 (1 reclocked and 2 processed)
Signal Level	800mV nominal
DC Offset	0V \pm 0.5V
Rise and Fall Time	200ps nominal for HD
Overshoot	< 10% of amplitude
Return Loss	> 15dB up to 1.0Gb/s, > 10dB up to 1.5Gb/s
Wideband Jitter	< 0.2UI

Reference Video Input

Standard	PAL (ITU624-4), NTSC (SMPTE 170M)
Number of Inputs	2 on SFR18, 2 on SFR08, 1 on SFR04
Connector	BNC
Signal Level	1V nominal
Impedance	High impedance, with loop for termination
Return Loss	> 25dB to 10MHz

Miscellaneous

Weight	Approx. 250g
Operating Temperature	0 °C to +50 °C
Dimensions	137 x 296 x 20 mm (HxWxD)

Electrical

Voltage	+24V to +30V
Power	<10 Watts