

**Canon**

# HJ14ex4.3B

CAPTURE THE WORLD WITH THE NEXT GENERATION HD WIDE LENS



**INNOVATION**  
In TV Optics Since 1958

**HDXS**

# HJ14ex4.3B

# HXS



Over the past decade, as the demand for broadcast HDTV production has continued its steady growth, Canon's HJ11ex4.7B lens has been a popular HDTV wide-angle lens, earning a stellar global reputation for outstanding optical performance and ease of operation. Capitalizing on this legacy of imaging excellence, Canon is expanding the possibilities of HDTV origination with the launch of an even more advanced wide-angle lens, the HJ14ex4.3B. This is a totally new-generation lens design and is particularly innovative in combining an extended 14 times zoom range and unprecedented 4.3mm wide angle, with an enhanced overall optical performance. Unequalled image clarity and sharpness were the design goals. Even the digital drive-unit is newly developed to provide streamlined ergonomics and ease of operation that further empowers camera operator shooting flexibility.

## MAIN FEATURES

### Widest Angle Lens To Date in the TV Industry

With a minimum focal length of 4.3mm the HJ14ex4.3 lens features the widest angle among presently available 2/3-inch lenses with an angular field of view of 96.3° in the 16:9 format at the wide end. This is significantly augmented with the 14x zoom range reaching to 60mm (120mm with extender), producing an unsurpassed operational combination that greatly expands HDTV production applications.

### Improved Optical Performance

The past decade has seen dramatic advances in powerful new 3D optical design tools, glass materials, design techniques (such as aspherical elements), and optical coatings. These new technologies allow the HJ14x lens to provide a wider angle and a higher zoom ratio than previous models, while also offering important optical performance enhancements:

- Higher resolution at both picture center and at the extremities of the 16:9 HD image plane
- Further minimization of chromatic aberrations and geometric distortion
- Less light falloff from picture center to corners, especially at wide angle settings
- Reduced focus breathing
- Curtailment of ghosting artifacts created by strong light sources

### Improved Operability & Reduced Operator Fatigue

Coupled with innovations in optical performance, is a totally new design of the digital drive unit. Refined by long-term market research and worldwide experience, Canon mobilized the latest in 3D CAD-CAM design to significantly improve the human tactile interface to the control of zoom, iris, and focus. Here are some results of Canon's research:

#### Reduced Physical Stress

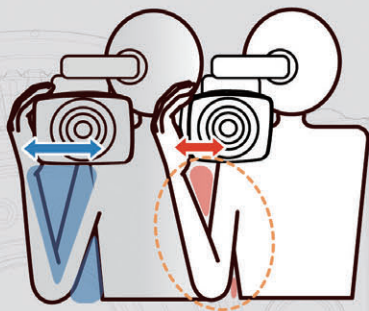

By reducing the width of the drive unit, the palm of the camera operator's hand is positioned closer to the optical axis, thus reducing the degree of arm bend which in turn lessens physical stress during prolonged shooting.

#### Ergonomic Design

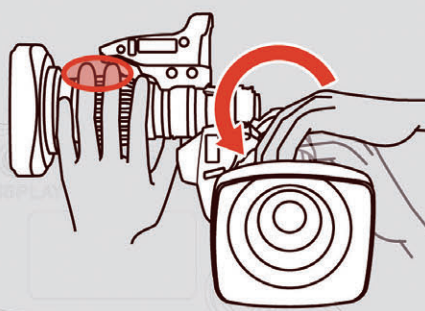

The spacing between the focus ring and drive unit has been changed to avoid accidental interference with the drive unit while manipulating the focus control.

#### Improved Ease of Operation

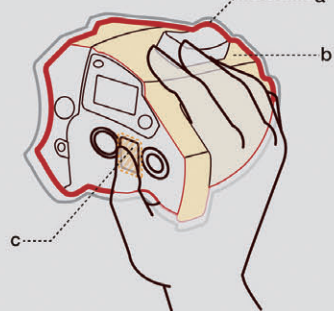

The size and curvature size have been optimized to more comfortably fit in the palm of the operator's hand (a). Newly developed coatings improve the tactile interface between the user and the drive unit (b) together with the new Rubber Grip Support (c).

### Smaller Hood Size and Higher Versatility

The HJ14ex4.3 uses a smaller hood unit compared to its predecessor. While increasing the versatility of the camera, this also helps the camera operator view the actual scene.

Hood Unit of HJ11ex  
Hood Unit of HJ14ex

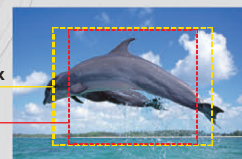

Angle Image of HJ11ex4.7B (91.2°)



New HJ14ex4.3B (96.3°)



Broad Focal Length  
of 4.3-60mm

**Enhanced Digital Drive Unit**

- Information Display
- Zoom Speed Volume in New Location
- New Rubber Grip Support



The incorporation of miniature 16-bit, high resolution Rotary Encoder Devices into the new enhanced digital drive unit, has extended the features of the HJ14x to include:

- Precision control of all lens operations
- Precise digital repeatability of zoom, focus and iris control that support innovative image creation
- Simple and direct digital integration into virtual studio systems
- Precision zoom control over a total speed range of 0.5 sec. to more than 5 min.

Moreover, Canon's unique Information Display provides easy, precise customization of the enhanced digital functions.

**Enhanced Digital Functions**

**Shuttle Shot**

By memorizing any two focal lengths, the Digital Drive can automatically "shuttle" between the two points, moving in either direction.



**Frame Preset**

An angle of view can be preset in either of two memories and the lens will zoom at the highest speed or in a preset zoom speed to the preset position by pushing a simple button.



**Speed Preset**

A specific zoom speed can be preset in memory and it is possible to repeat the zoom speed as often as you like by pushing a simple button.



Zooming in same speed



**Exceptional High Optical Performance**  
High MTF, Minimized Chromatic Aberrations and Countermeasures against Ghosting and Flares

**SPECIFICATIONS**

HJ14e×4.3B	NORMAL 16:9		SWITCHABLE 4:3	
	1.0X	2.0X	1.2X	2.4X
Built-in extender	1.0X	2.0X	1.2X	2.4X
Zoom Ratio	14X			
Range of Focal Length	4.3~60mm	8.6~120mm	4.3~60mm	8.6~120mm
Maximum Relative Aperture	1:1.8 at 4.3~40mm 1:2.7 at 60mm	1:3.6 at 8.6~80mm 1:5.4 at 120mm	1:1.8 at 4.3~40mm 1:2.7 at 60mm	1:3.6 at 8.6~80mm 1:5.4 at 120mm
Angular Field of View	96.3°×64.2° 9.1°×5.2°	58.3°×34.9° 4.6°×2.6°	79.9°×64.2° 6.9°×5.2°	45.4°×34.9° 3.4°×2.6°
Minimum Object Distance (M.O.D)	0.3m (10mm with Macro)			
Object Dimensions at M.O.D	76.4×43.0cm at 4.3mm 5.2×2.9cm at 60mm	38.2×21.5cm at 8.6mm 2.6×1.5cm at 120mm	57.3×43.0cm at 4.3mm 3.9×2.9cm at 60mm	28.7×21.5cm at 8.6mm 2.0×1.5cm at 120mm
Approx. Size	W×H×L = 163.5×110.8×247.8 mm			
Approx. Mass (IRSE/IASE)	1.99Kg (4.39lbs) / 2.07kg (4.56lbs)			

HJ14ex4.3B IRSE Zoom: Servo / Manual Focus: Manual  
HJ14ex4.3B IASE Zoom: Servo / Manual Focus: Servo / Manual

## ACCESSORIES

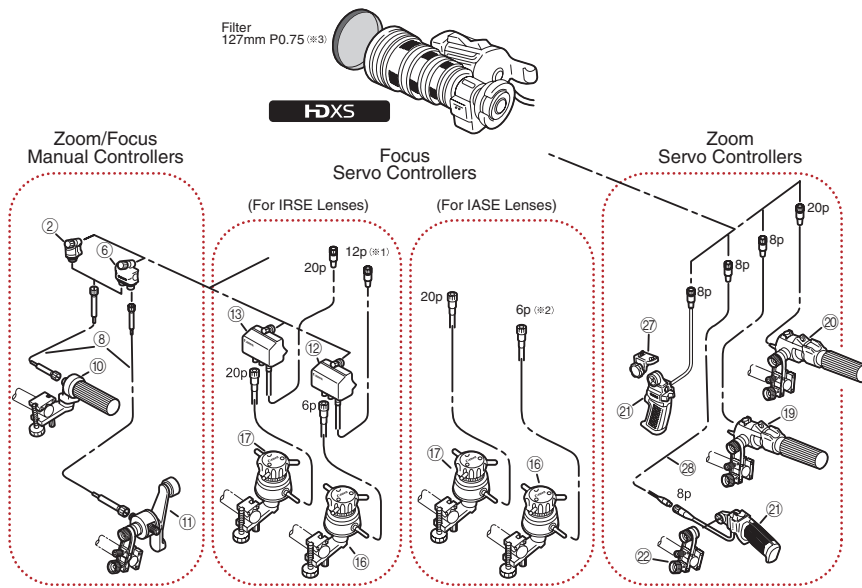

(※1) CC-2012 conversion cable is necessary to connect between IRSE Digital Drive Lens and FPM-420.

(※2) CC-2006 conversion cable is necessary to connect between IASE Digital Drive Lens and FPD-400.

(※3) For the optical accessories, the 127mm diameter P0.75 filters are applicable. The filters are to be attached to the threaded hood unit. (UV/ Clear/ Cross/ Snow Cross/ Sunny Cross/ Polarized Light/ Softon/ ND8)

(※4) FPD-400 is not available from Canon stock.

#	Unit	Description
②	FFM-100	Flex Focus Module
⑥	FFM-200	Flex Dual Module
⑧	FC-40	Flex Cable
⑩	FFC-200	Flex Focus Controller
⑪	FZC-100	Flex Zoom Controller
⑫	FPM-420	Focus Positional Servo Module
⑬	FPM-420D	Focus Positional Servo Module
⑯	FPD-400 <sup>※4</sup>	Focus Positional Demand
⑰	FPD-400D	Focus Positional Demand
⑲	ZSD-300M	Zoom Servo Demand
⑳	ZSD-300D	Zoom Servo Demand
㉑	ZSG-200M	Zoom Servo Grip
㉒	CR-10	Clamper
㉔	ZGA-500	Grip Adapter
㉘	EC-80	Zoom Extension Cable (8P)

## DIMENSIONS

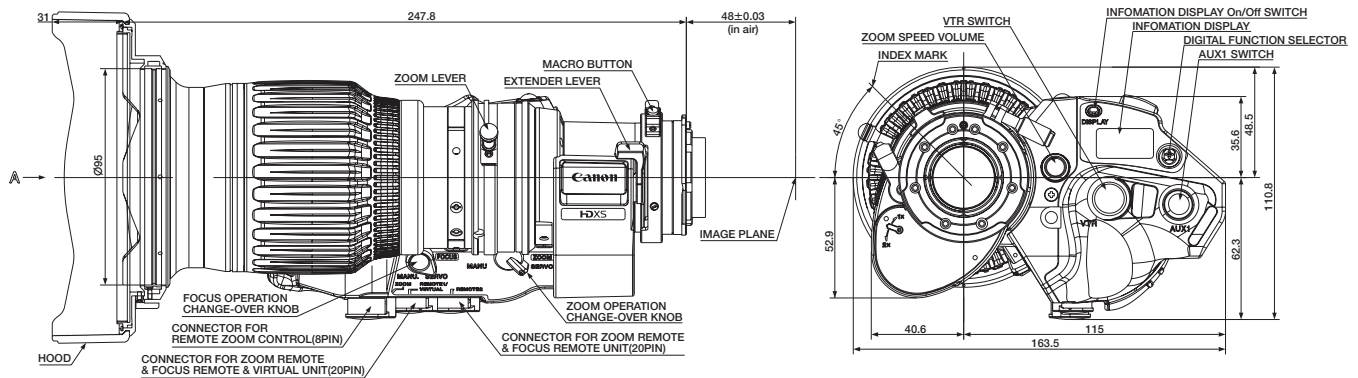

### North & South America Canon U.S.A., Inc.

Broadcast & Communications Div. (Headquarters)  
65 Challenger Road, Ridgeland Park, NJ 07660  
Tel: (201) 807-3300 / (800) 321-4388  
Fax: (201) 807-3333  
Email: bctv@usa.canon.com  
http://www.canonbroadcast.com/

### Chicago

100 Park Blvd. Itasca, IL 60143  
Tel: (630) 250-6236 Fax: (630) 250-0399

### Atlanta

5625 Oakbrook Pkwy. Norcross, GA 30093  
Tel: (770) 849-7890 Fax: (770) 849-7888

### Los Angeles

15955 Alton Parkway Irvine, CA 92618  
Tel: (949) 753-4330 Fax: (949) 753-4337

### Dallas

3200 Regent Blvd. Irving, TX 75063  
Tel: (972) 409-8871 Fax: (972) 409-8869

### Latin America

Tel: (954) 349-6975 Fax: (201) 807-3333

### Canada

**Canon Canada, Inc.**  
Broadcast and Communications Div.  
6390 Dixie Road  
Mississauga, Ontario, L5T 1P7, Canada  
Tel: (905) 795-2012 Fax: (905) 795-2140

### Europe/Africa/Middle East Canon Europa N.V.

Broadcast and Communications Div.  
Bovenkerkerweg 59-61  
1185 XB Amstelveen  
Tel: +31 (0) 20-5458905 Fax: +31 (0) 20-5458203  
Email: tvprod@canon-europe.com  
http://www.canon-europe.com/tv-products

### Australia Canon Australia Pty. Ltd.

Optical Products Division  
1 Thomas Holt Drive, North Ryde, NSW 2113,  
Australia  
Tel: +61 (0) 2-9805-2000 Fax: +61 (0) 2-9805-2444

### China Canon (China) Co., Ltd.

Optical Products Division  
15F Jinbao Building No.89 Jinbao Street  
Dongcheng District, Beijing 100005, China  
Tel: 86-10-85139999 Fax: 86-10-85139902  
http://www.canon.com.cn

### Asia/Japan Canon Inc. (Broadcast Equipment Group)

23-10, Kiyohara-Kogyo-Danchi, Utsunomiya-shi,  
Tochigi-ken, 321-3298, Japan  
Tel: +81 (0) 28-667-8669 Fax: +81 (0) 28-667-8672  
http://www.canon.com/bctv

Distributed by

Specifications subject to change without notice.

# Canon

